

Sullair Air Tools

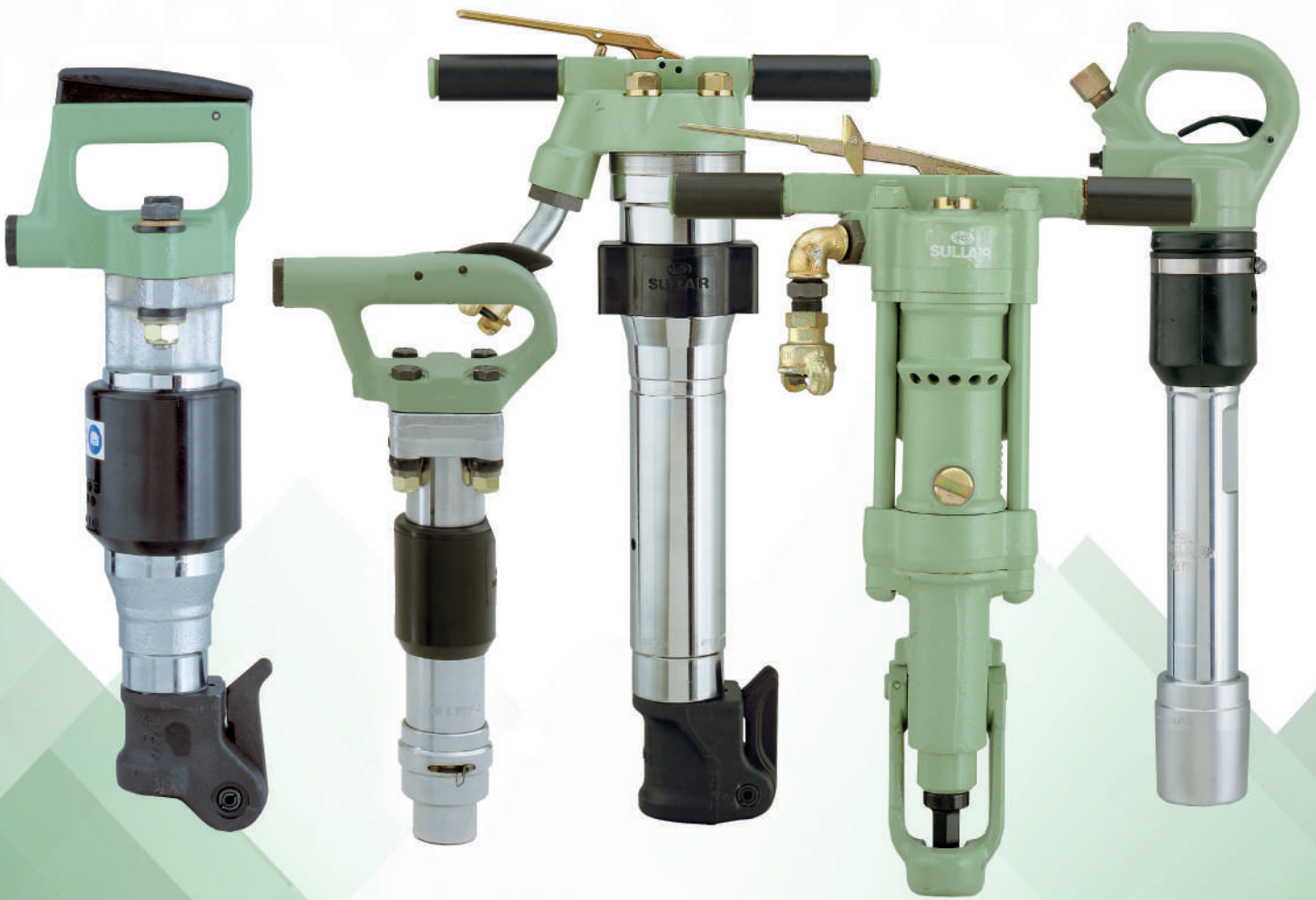

 **SULLAIR**[®]
Always air. Always there.[®]

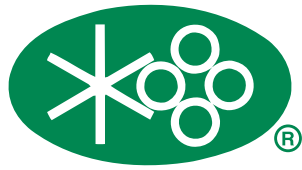

SULLAIR®

Always air. Always there.®

The Right Tool for Your Tough Job

Applications	Tool	Sullair Model	Class	Weight	cfm
<ul style="list-style-type: none">Horizontal and overhead applicationsIndustrial applications	Chipping Hammer	MCH-2/3/4 MCH-3S/4S	15#	16-19 lbs	26-33
<ul style="list-style-type: none">Cutting and driving large rivetsHeavy duty demolition work	Rivet Buster	MRB-8/11	30#	30-33 lbs	44-50
<ul style="list-style-type: none">Breaking light concrete and other light jobs	Light Pavement Breaker	MPB-30A	30#	35.5 lbs	37
<ul style="list-style-type: none">Concrete bridge decks and general demo work	Light Pavement Breaker	MPB-35A	40#	39 lbs	49
<ul style="list-style-type: none">Concrete road breaking and other general demo work	Medium Pavement Breaker	MPB-60A MPB-60AS	60#	69.5 lbs	48
<ul style="list-style-type: none">Heavy demo work breaking tough, reinforced concrete	Heavy Pavement Breaker	MPB-90A MPB-90AS	90#	92 lbs	62
<ul style="list-style-type: none">Excavation of clay and hardpanLight horizontal demolition work	Light Demolition Tool	MDT-22	20#	24.7 lbs	33.4
<ul style="list-style-type: none">Medium demolition work	Medium Demolition Tool	MDT-30	30#	33 lbs	37
<ul style="list-style-type: none">Compacting backfill in ditches, trenches, foundations and around poles	Backfill Tamper	MBT-6	35#	40.5 lbs	32
<ul style="list-style-type: none">Setting anchorsDrilling holes in concrete and bricks	Hammer Drill	MRD-9	9#	9 lbs	21
<ul style="list-style-type: none">Setting anchorsDrilling holes in concrete and bricks	Light Rock Drill	MRD-30	30#	34 lbs	53
<ul style="list-style-type: none">Drill for depths up to 6 feet and 1-1/2" diameter	Light Rock Drill	MRD-40	40#	45.5 lbs	80
<ul style="list-style-type: none">Drill for depths up to 10 feet and 1-3/4" diameter	Medium Rock Drill	MRD-50	50#	48.5 lbs	123

Drills Designed for Performance and Operator Protection

Dead Man Safety Handle

Sullair drills are designed so that the tool automatically stops operating when the operator releases the throttle lever.

One Control for Drilling and Blowing

The single throttle lever controls all tool functions from off, to blowing only, to progressive drilling speeds.

Variable Throttle Control

Allows step less speed control for maximum drilling production.

Continuous Hole Cleaning

Blowing air is directed through the drill rod at all drilling speeds to clear debris from the hole.

Direct Rotation of the Piston

This feature reduces torque loss and eliminates wearing parts, such as the rifle bar assembly.

Less Maintenance

The unique design of Sullair drills eliminates many high wear parts. This means less loss of power due to wear, less downtime to replace worn parts and lower overall maintenance costs.

Minimal Lubrication Required

With only two parts moving during operation, a non-corrosive distribution valve, less radial piston movement and high tech alloys, Sullair drills do not require special rock drill oil. Normal oil carryover from the compressor, combined with moisture in the air, will usually provide sufficient lubrication under normal operating conditions.

Oil Reservoir

A built-in oil reservoir assures direct lubrication to rotating parts. Use of standard 90 to 140-weight gear lubricant extends the life of critical parts.

Simplified Ratchet Design

The M-Series Rock Drills are designed to eliminate conventional spring ratchet systems by spreading the torque over four check pawls increasing durability.

One-Year Parts Warranty

This Sullair warranty covers all drill parts against normal wear and manufacturing defects for one-year.

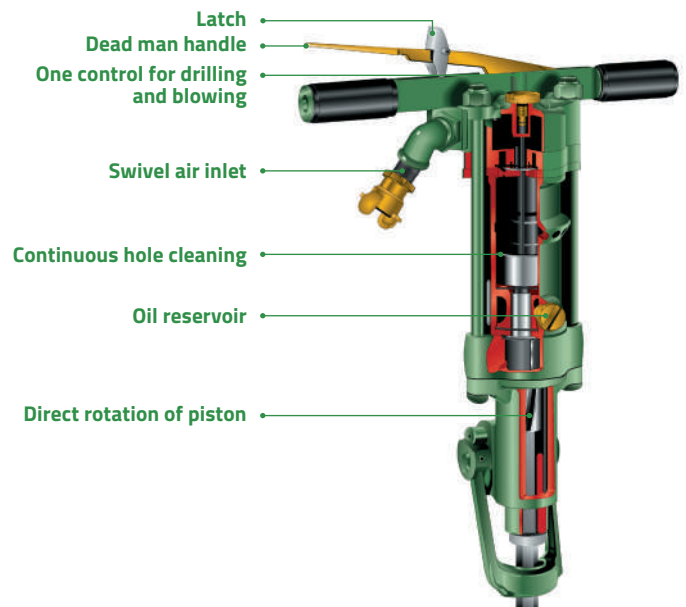

TECHNICAL SPECIFICATIONS

Drilling Hammers

Model	Part Number	Chuck Size (in)	Bore & Stroke (in)	Blows per minute	Air Consumption (cfm)	Air Inlet (NPT)	Weight (lbs)	Length (in)
MRD-9	68252232	3/4" Round x 3-3/4"	1-1/32" x 1-3/8"	2800	21	3/8"	9	15-1/8"
MRD-30	68252230	7/8" x 3-1/4"	2-9/32" x 1-3/4"	2300	53	3/4"	34	21"
	68253073	7/8" x 4-1/4"	2-9/32" x 1-3/4"	2300	53	3/4"	34	21"
MRD-40	68252227	7/8" x 3-1/4"	2-11/16" x 2-3/8"	1800	80	3/4"	45.5	23-1/8"
	68252228	7/8" x 4-1/4"	2-11/16" x 2-3/8"	1800	80	3/4"	45.5	23-1/8"
	68252229	1" x 4-1/4"	2-11/16" x 2-3/8"	1800	80	3/4"	45.5	23-1/8"
MRD-50	68252224	7/8" x 3-1/4"	3" x 2-5/8"	1800	99	3/4"	48.5	23-1/4"
	68252225	7/8" x 4-1/4"	3" x 2-5/8"	1800	99	3/4"	48.5	23-1/4"
	68252226	1" x 4-1/4"	3" x 2-5/8"	1800	99	3/4"	48.5	23-1/4"

MRD-9 Accessories

Part Number	Description
WHIP HOSE ASSEMBLIES, 8' x 1/2" ID. 300 psi rated hose	
02250152-585	3/8" MNPT air inlet swivel
WHIP HOSE WITH SWING COUPLING, 8' x 1/2" ID hose w 1' whip	
02250139-712	3/8" MNPT air inlet with swing coupling x 2-lug universal quick connect

MRD-30, MRD-40 & MRD-50 Accessories

Part Number	Description
WHIP HOSE WITH SWING COUPLING, 8' x 1/2" ID hose w 1' whip	
02250139-714	2-lug universal air inlet with swing coupling x 2-lug universal quick connect



Pneumatic Tool Accessories

Line Oiler and In-Line Filter

Part Number	Description
251309	1/6 Pint capacity (1/2" FNPT-Pressure Feed)
251310	1/3 Pint capacity (3/4" FNPT-Pressure Feed)
251311	1/2 Pint capacity (3/4" FNPT-Pressure Feed)
251312	1/2 Pint capacity (1" FNPT-Pressure Feed)
251313	1 Pint capacity (1" FNPT-Pressure Feed)
251314	1/2 Pint capacity (1" FNPT-Constant Feed)
251315	1 Pint capacity (1" FNPT-Constant Feed)
02250138-177	In-line hose filter (1/2" FNPT)

Tool Stand

02250114-793	Tool Stand, 3 tool
--------------	--------------------

Butts for MBT-6 Backfill Tamper

68722625	6" Dia. Butt-Steel
250034-467	Half-Moon Pole Butt-Malleable Iron
250034-783	6" Dia. Butt-Malleable Iron
250034-784	4" Dia. Butt-Aluminum
250034-785	3" Dia. Butt-Aluminum
250035-320	5" Dia. Butt-Neoprene
250012-703	Screw, Taper

Air Inlet Swivels for Chippers, Tampers

250012-531	7/8"-24 thread—1/2" hose barb
250012-532	3/8" NPT—1/2" hose barb
250012-533	1/2" NPT—1/2" hose barb

Retainers and Accessories for Chipping Hammers

68722235	Retainer, for oval collar steel-chrome finish
250012-526	Retainer, for round collar steel w/ bumper
250018-984	Rubber bumper replacement for round collar retainer
250021-222	Retainer, universal ball type (spring)
250012-530	Lock Spring, heavy duty
250013-916	Lock Spring, plastic
68780341	Retainer, universal ball type (screw-on)

Retainers and Accessories for Rivet Busters

250035-776	Retainer
250029-072	Upper Sleeve 11X
250013-625	Lower Sleeve 11X
250013-626	Bumper
250013-594	Retainer spring
02250166-693	Kit, Rivet Buster Lower End

Air Hose, Couplings, Fittings and Accessories, 300psi Rated Hose

Part Number	Description
02250152-581	50' 2-lug universal quick connect at both ends
02250152-583	100' 2-lug universal quick connect at both ends

Whip Hose Assemblies, 8' x 1/2" ID. 300 psi Rated Hose

02250152-585	3/8" MNPT air inlet swivel
02250152-586	1/2" MNPT air inlet swivel x 2-lug universal quick connect
02250152-584	7/8"-24 male thread inlet swivel x 2-lug universal quick connect

Whip Hose Assemblies, 6' x 1/2" ID. 300 psi rated hose (steel hyd. Swivel)

02250176-106	3/8" MNPT steel hydraulic swivel w/ 7/8" bushing x 2-lug universal quick connect
--------------	----------------------------------------------------------------------------------

Whip Hose Assembly with 1/6 pt Oiler, 8' x 1/2" ID. 300 psi rated hose

02250174-410	3/8" MNPT air inlet swivel x 2-lug universal, w/ oiler (251309)
02250174-411	1/2" MNPT air inlet swivel x 2-lug universal, w/ oiler (251309)
02250174-412	7/8"-24 male thread inlet swivel x 2-lug universal, w/ oiler (251309)

Whip Hose with Swing Coupling, 8' x 1/2" ID hose w 1' whip

02250139-711	7/8"-24 male thread air inlet with swing coupling x 2-lug universal quick connect
02250139-712	3/8" MNPT air inlet with swing coupling x 2-lug universal quick connect
02250139-713	1/2" MNPT air inlet with swing coupling x 2-lug universal quick connect
02250139-714	2-lug universal air inlet with swing coupling x 2-lug universal quick connect

Additional 1' Whip Hose for Above Swing Couplings

02250139-707	7/8"-24 fitting and valve plug
02250139-709	1/2" MNPT fitting and valve plug
02250139-710	2-lug fitting and valve plug

Bulk Hose on Reel

02250152-580	3/4" x 400' Sullair Green Hose - 300 psi
--------------	------------------------------------------

Hose Fittings, Clamps and Repair Kits

250031-649	1/2" Hose barb, 2-lug universal quick connect
250031-650	3/4" Hose barb, 2-lug universal quick connect
250031-654	3/4" Hose barb, 2-bolt style clamp
02250113-961	Coupling, 2-lug universal quick connect—3/8" MNPT
02250140-797	Coupling, 2-lug universal quick connect—3/8" FNPT
02250126-794	Coupling, 2-lug universal quick connect—1/2" MNPT
040383	Coupling, 2-lug universal quick connect—3/4" FNPT
250031-648	Coupling, 2-lug universal quick connect—3/4" MNPT
250015-228	Gasket, rubber—for 2-lug universal coupling (package of 50) sold per pkg
250031-659	Clip, hose coupling, safety (package of 25) sold per pkg
02250119-544	HOSE REPAIR KIT (includes following): 50 ea. 1/2" hose clamp, 40 ea. 3/4" hose clamp, 6 ea. 1/2" hose mender, 6 ea. 3/4" hose mender, and 1 ea. Toll pincher long handle
02250119-543	Hose clamp pincher tool (long handle)
02250119-541	1/2" Hose mender (tube)
02250119-542	3/4" Hose mender (tube)
02250119-863	3/4" Hose clamp (package of 100)

CONTACT YOUR  **SULLAIR**® DISTRIBUTOR TODAY